



ADVANTAGES

- Fast start for new employees
- Comprehensive structural pressure vessels analysis
- Integration with popular CAD tools
- Flexible licensing
- Affordable price

FEATURES

- Quick stress and stability analysis of vessels, columns, heat exchangers and tanks
- Nozzle FEM analysis to evaluate stiffness, stress and allowable loads
- Vast databases of standard elements and materials
- Powerful 3D modeling with export to various formats
- Detailed calculation reports ready for delivering to any authorities
- Intuitive user interface

PASS/EQUIP combines sophisticated calculation capabilities and code compliance with ease-of-use to deliver simulation of pressure vessels for strength and stability by even entry-level engineers and designers.

EMBEDDED INTELLIGENCE

PASS/EQUIP provides pressure vessel strength and stability analysis for horizontal and vertical vessels, columns, storage tanks, as well as shell-and-tube and air cooled heat exchangers under static and seismic loads in order to evaluate bearing strength in operation, test, and assembly states.

Applications include designing, revamping and testing of vessels, as well as making compliance calculations for power, oil-refining, chemical, petrochemical, natural gas, petroleum and other related industries.

PASS/EQUIP also provides finite element analysis of arbitrary vessel nozzles for the purpose of estimating their stress, stiffness, and allowable loads. The results can be imported into PASS/START-PROF to be used for piping stress analysis.

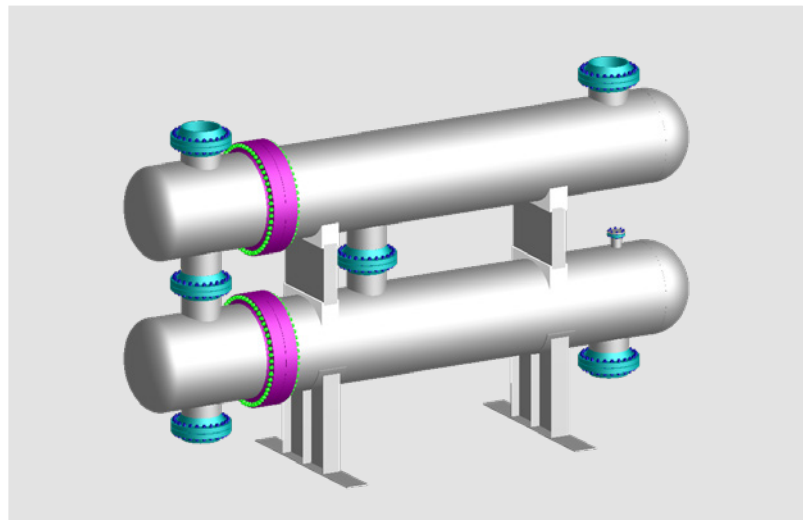

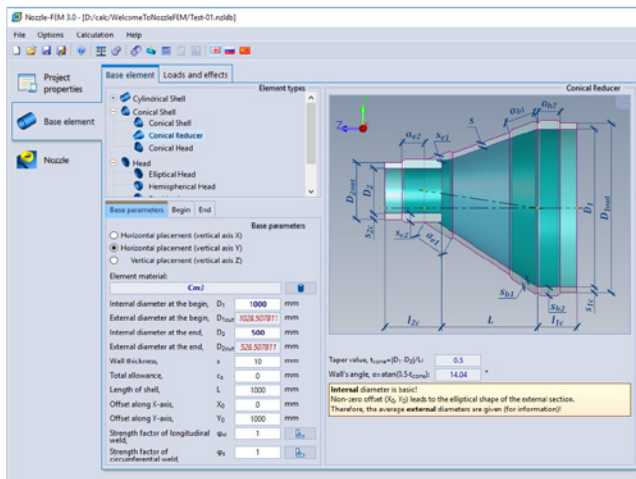

POWERFUL CAPABILITIES

PASS/EQUIP performs strength and stability calculation of horizontal, vertical, and column vessels, and takes into account wind and seismic loads. PASS/EQUIP also calculates the strength and stability of shell-and-tube heat exchangers, including tubesheets, tubes, pass partitions, shells, expansion bellows, expansion boxes, and floating heads.

The smart tube grid editor of heat exchanger provides very powerful opportunities of non-standard tubesheets modeling.

PASS/EQUIP provides analysis of nozzle-to-shell junctions using the Finite Element Method (FEM) including calculation of allowable nozzle loads and estimated nozzle junction strength for a wide range of geometric configurations and operating conditions. PASS/EQUIP nozzle analysis is recommended for the design and industrial safety review of oil and gas, refining, petrochemical, chemical, power and other industrial facilities.

PASS/EQUIP performs stress analysis for nozzles (including trunnions) of arbitrary geometry connected to cylindrical and conical shells, as well as elliptic, hemispherical and flat heads and performs nozzle-shell junction flexibility calculations. Nozzle and shell membrane stress, bending stress and total stress can be calculated.

INCREASED PRODUCTIVITY

PASS/EQUIP does not require special training and can be used by any mechanical engineer. It provides the ultimate in usability by even entry-level engineers allowing them to focus on the equipment design.

The user defines the equipment type, geometrical adjectives, and material of the vessel components, type and allocation of supports, test type, and loading rates. Selection of vessel elements and materials is made from the vast databases which can be updated by the user.

For nozzles, the creation of finite element mesh and estimation of calculation results are performed automatically.

3D graphic display of equipment geometry is provided with the possibility of editing the color of separate elements or the whole model, with views to make it possible to see internal elements.

Powerful 3D modeling opportunities also support export to various CAD formats, so the user could continue work on vessel design in his favorite CAD environment.

Detailed calculation reports produced by the program contain comprehensive information (including all equations, intermediate results, and plot of forces and moments) and are ready to be delivered to any authorities or equipment certification bodies.

FLEXIBLE CONFIGURATIONS

PASS/EQUIP Complete provides stress analysis for vessels, columns, heat exchangers, tanks and nozzles.

PASS/EQUIP Tank provides stress analysis for vessels, tanks and nozzles.

PASS/EQUIP Vessel&Exchanger provides stress analysis for vessels, heat exchangers and nozzles.

PASS/EQUIP Vessel provides stress analysis for vessels and nozzles.

PASS/EQUIP Nozzle-FEM provides FEM analysis for nozzle and vessel connections.

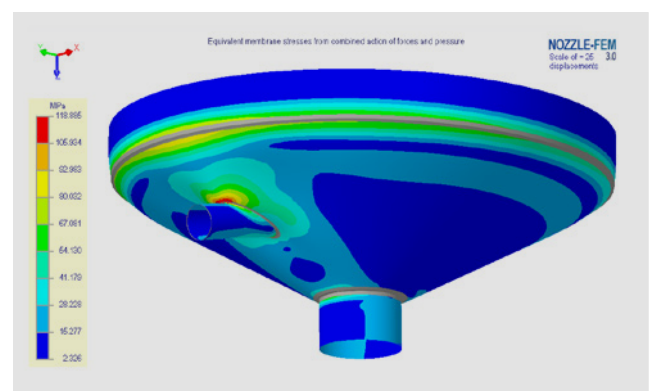

**FIND MORE INFORMATION ABOUT
PASS SUITE IN SOCIAL MEDIA**

-  www.youtube.com/passuite
-  www.facebook.com/passuite
-  www.linkedin.com/company/passuite